

Diritti riservati All rights reserved

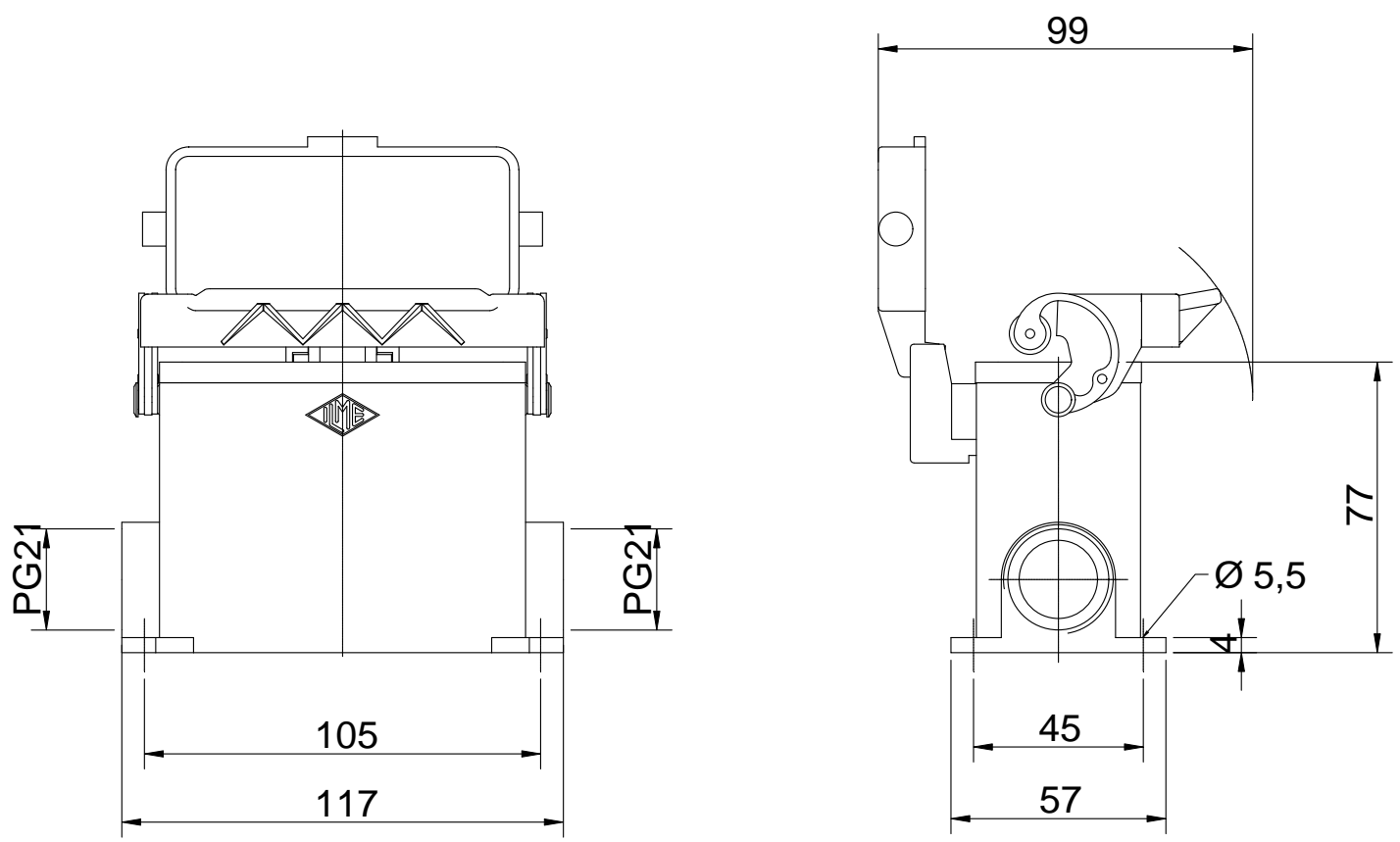

Date 04.01.2007	CMAP 06 LS2		Scale
Sign.	surface mount.h.1 lev.+cov.2xPG21 ins.		1:2